

Phase and Polarization Diversity for OCDMA

A. Brinton Cooper III, Jacob B. Khurgin, Jin U. Kang

Department of Electrical and Computer Engineering, The Johns Hopkins University, Baltimore, MD 21218,
410-516-7014(V)/5566(F), abcooper@jhu.edu

Abstract. A phase sensitive receiver for Optical Code Division Multiplexing (OCDMA) waveforms generated by spectral phase coding (SPC) using phase and polarization diversity offers expanded system capacity due to low values of multiple access interference (MAI).

©Optical Society of America

OCIS codes: (060.2330) Fiber Optics Communications;

1 Spectral Phase Coding for OCDMA

The potential for OCDMA to increase system capacity, security, and flexibility is significantly limited by multiple access interference (MAI) [1]. In RF wireless communications, CDMA achieves spectral efficiencies that exceed those of fiber OCDMA by an order of magnitude because the RF receiver recovers transmitted data by coherent correlation processing of the time domain BPSK chip sequence. Direct detection optical systems destroy phase, precluding coherent processing. In principle, modulating the phase and/or frequency of an optical pulse train with the same orthogonal sequence sets offers lower levels of MAI than are possible in current designs. However, phase coherent correlation processing of spectrally encoded OCDMA faces the

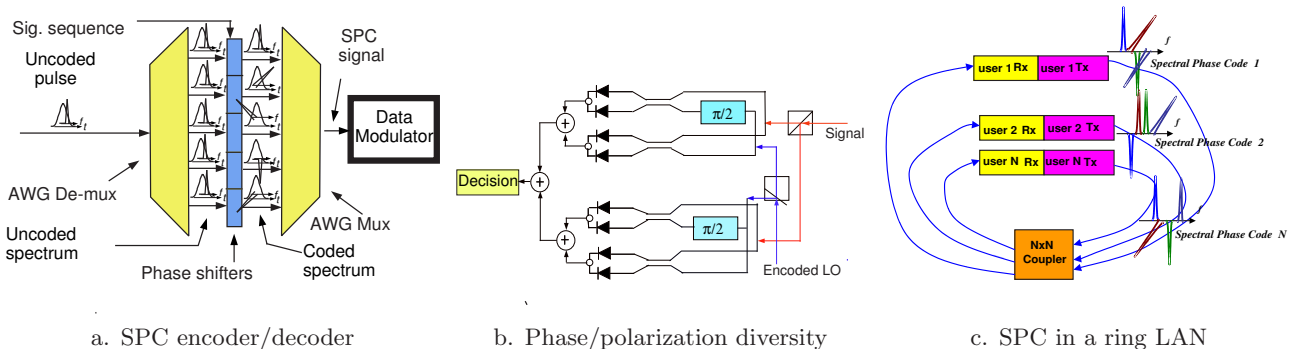

Figure 1: OCDMA implementation using SPC

challenges of realizing an optical phase locked loop and compensating for polarization fluctuations in the received signal and phase noise in the transmitter and local oscillator (LO). Alternatively the received signal can pass through an encoder using the correct code, giving a sharp peak that can be discerned by a very fast, nonlinear peak detector. In fact, usefully low bit error rates have been demonstrated for optical phase coding with such a detector [2] but the MAI in that scheme is still very large because interfering codes produce a large background level. Hence, spectral efficiency achieved in [2] was less than 0.01 bps/Hz. In this work we propose a fully orthogonal coherent OCDMA scheme that does not require sophisticated nonlinear optical elements or phase tracking, yet achieves high spectral efficiency and other performance metrics associated with CDMA. This system can be realized in a compact, low cost design.

2 SPC Implementation

At the transmitter, an AWG [4] demultiplexer (Fig. 1a) spatially decomposes the line spectrum (Fig. 2) of a rate $(1/T)$ stream of duration T_d optical pulses. The central N out of $2T/T_d$ spectral lines in the main lobe are BPSK encoded (using, *e.g.*, an array of slow thermo-optical phase modulators) by a signature sequence from a pairwise orthogonal set [6]. An AWG multiplexer recombines the encoded spectrum into a time spread pulse of duration $\leq T$ (Fig. 2). This pulse sequence is then modulated with an OOK data stream.

In the receiver, received and identically SPC encoded LO signals are split into oppositely polarized components. A phase and polarization diversity (PPD) [5] correlator (Fig. 1b) removes phase and

polarization fluctuations between LO and signal. Each component of the received signal is mixed with delay-orthogonal versions of the LO in a set of balanced detectors that integrate over each bit; hence, full homodyne detection is achieved over each bit interval, offering much lower MAI levels than present OCDMA receivers, thereby achieving competitive degrees of concurrency. Let \mathbf{E}_L and \mathbf{E}_s be the modulated LO and received signals, respectively. The squared outputs of each of the four balanced detectors are: $(\mathbf{E}_L \star \mathbf{E}_s \cos \phi \cos \theta)^2$, $(\mathbf{E}_L \star \mathbf{E}_s \sin \phi \cos \theta)^2$, $(\mathbf{E}_L \star \mathbf{E}_s \cos \phi \sin \theta)^2$, and $(\mathbf{E}_L \star \mathbf{E}_s \sin \phi \sin \theta)^2$ where ϕ is the relative phase delay between \mathbf{E}_L and \mathbf{E}_s and θ is the relative polarization angle. As shown, these are summed and the phase ambiguities disappear, leaving a term proportional to $(\mathbf{E}_L \star \mathbf{E}_s)^2$. The integration (filtering) of the square sum is equivalent to the inner product of the vector signals since the spectral lines are orthogonally spaced.

A system of 32 users at 10 Gb/s with 1.0 ps optical pulses at $f_c = 300$ THz was considered. Of the 200 lines in the spectral main lobe, 32 were SPC-encoded using Hadamard-Walsh [6] sequences of length 32. The MAI level (in dB) produced by each user, relative to the level of the received signal, is shown in Fig. 3. When all 31 interferers are present, the signal-to-MAI power ratio is 12.7 dB. It has been determined by numeric experimentation that increasing the sequence length by including more lines reduces the MAI, but the reduced amplitudes of the additional lines become problematic with respect to system noise. In fact, the main spectral lobe contains 0.97 of the total energy in the pulse, and the energy between ± 0.16 of the zero crossings of the lobe (corresponding to 32 of the 200 spectral lines) contains 0.78 of the total pulse energy.

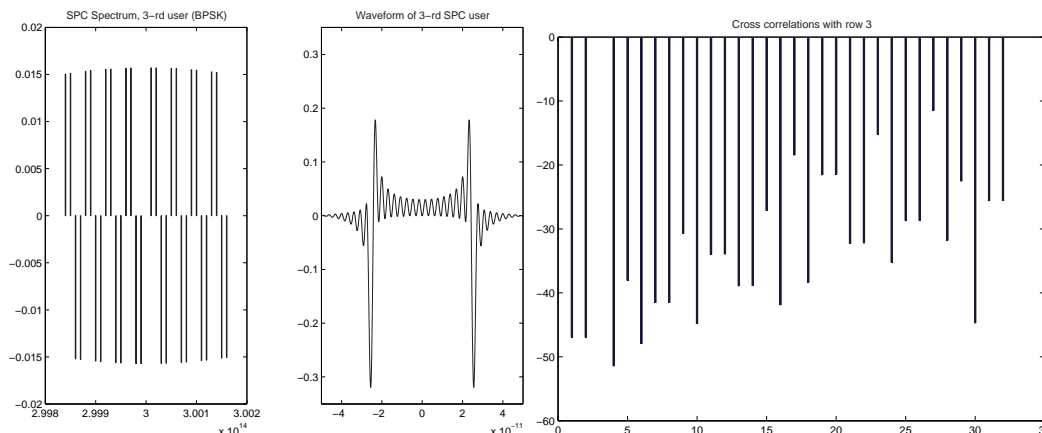

Figure 2: SPC spectrum and waveform

Figure 3: Relative MAI levels (dB)

SPC is attractive in local area networks of moderate span, where phase distortion in nonlinear amplifiers is not present. Fig. 1c shows a typical LAN using SPC transceivers.

3 Conclusion

We have proposed and modeled a novel, fully orthogonal OCDMA scheme that offers low MAI, high spectral efficiency, and simplicity.

References

- [1] C.F. Lam, *et al*, *IEEE Photon. Technol. Lett.*, **10**, 1041 (1998).
- [2] V.J. Hernandez, *et al*, *J. Lightwave Technol.*, **22**, pp 2671-2679, (2004).
- [3] S. Verdú, *Multuser Detection*, Cambridge Univ. Press, Cambridge (1998).
- [4] T. Mizuno, *et al*, *Electron. Lett.*, **37**, pp 1452-1454, (2001).
- [5] L.G. Kazovsky, *IEEE J. Lightwave Technol.*, **7**, pp 279-92 (1989).
- [6] S.-H. Tsai, Y.-P. Lin, and C.-C. Jay Kuo, *Proc. IEEE 60th Vehicular Technology Conference*, **6**. 4335-4330 (2004).