

# 10Gbps-Class, Bandwidth-Symmetric, OCDM-PON System using Hybrid Multi-port and SSFBG En/Decoder

Nobuyuki Kataoka, *Member, IEEE*, Naoya Wada, *Member, IEEE*, Xu Wang, *Senior Member, IEEE*, Gabriella Cincotti, *Senior Member, IEEE*, and Ken-ichi Kitayama, *Fellow, IEEE*

**Abstract**— A next generation access network becomes necessary to upgrade the systems, providing a larger dedicated bandwidth to each user. Optical code division multiple access (OCDMA) is one promising candidate for new-generation broadband multiple access technique with unique features of full asynchronous transmission, low latency access, soft capacity on demand as well as optical layer security. Recently, a cost-effective OCDMA system using a single multi-port en/decoder at an optical line terminal (OLT) and superstructured fiber Bragg grating (SSFBG) encoder/decoders at each optical network unit (ONU) in an optical network has been proposed and demonstrated.

In this paper, we report our proposed 10 Gbps-class, bandwidth-symmetric, OCDM-PON system, which includes a system configuration and the characteristics of multi-port and SSFBG encoder/decoder. Moreover, we describe the demonstration of 8x8 full-duplex, asynchronous, 10Gbps, DPSK-OCDMA system over 50km transmission.

**Index Terms**— optical code division multiple access (OCDMA), passive optical network (PON), SSFBG

## I. INTRODUCTION

A symmetric Gigabit fiber-to-the-home (FTTH) service is required to meet the demands of future high bit rate applications such as uncompressed 1.2-Gb/s high-definition (HDTV) class or even 6-Gb/s 4K digital cinema on a peer-to-peer basis as well as bidirectional medical applications of telediagnosis and surgery [1].

For current passive optical network (PON) deployments, the industry has selected time division multiplexing (TDM) PON, which achieves cost effectiveness due to the user-shared cost-effective facilities [2]. However, TDM-PON system would be difficult to simultaneously provide all the customers with a gigabit-class bandwidth uplink due to the nature of the timeslot-based multiple access protocol. Therefore, TDM-PON will not be a solution to the 10 Gbps-class, symmetric FTTH system.

Wavelength division multiplexing (WDM-) PON is a natural approach to enhance the uplink capacity. WDM-PON creates point-to-point links between an optical line terminal (OLT) and each optical network unit (ONU) by uniquely assigning a wavelength to the user. Coarse WDM (CWDM) with the wavelength spacing of 20 nm in the spectral range from 1270 to 1610 nm has been linked with the PON architecture by International Telecommunication Union (ITU) G.983.3 [3]. However, the number of wavelengths is only 18, which may not be sufficient for the future multiple access

system, which accommodates even a moderate number of users.

Optical code division multiple access (OCDMA) technique is one promising candidate for gigabit-symmetric FTTH [1, 4]. It has unique features of full asynchronous transmission, low latency access, soft capacity on demand as well as optical layer security. There are two different approaches for the multi-user coherent OCDMA system: synchronous and asynchronous OCDMA. In the synchronous OCDMA, proper timing coordination is required to carefully avoid the overlaps between signal and interferences [5, 6]. In contrast, the asynchronous capability is essential in practical OCDMA systems [1, 4, 7].

Recently, for the coherent time-spreading (TS-) OCDMA, the multi-port OCDMA encoder/decoder (E/D) has the unique capability of simultaneously processing multiple time-spread optical codes (OCs) with single device [8], which makes it a potential cost-effective device to be used in the OLT of an OCDMA network to reduce the number of encoder/decoders. Meanwhile, the phase-shifted superstructured fiber Bragg grating (SSFBG) E/D is another attractive TS-OCDMA E/D, which has the ability to process ultra-long TS-OC with polarization independent performance, low and code-length independent insertion loss, compactness as well as low cost for mass production [9]. Recently, we have proposed hybrid using different types of the E/D in an OCDMA network is expected to significantly improve the system flexibility and performance [10].

In this paper, a Next-Generation bandwidth-symmetric FTTH system is studied. We report our proposed 10 Gbps-class, bandwidth-symmetric, OCDM-PON system using the hybrid multi-port and SSFBG encoder/decoder. Moreover, we describe the experimental result of full-duplex, asynchronous, 10Gbps, OCDM-PON system over 50km transmission.

## II. OCDM-PON SYSTEM WITH HYBRID MULTI-PORT AND SSFBG ENCODER/DECODER

### A. System configuration

Figure 1 shows the architecture of the proposed OCDM-PON system using hybrid (a) multi-port E/D and (b) SSFBG E/Ds. The multi-port encoder with periodic frequency response can be used in the OLT to process multiple OCs in multiple wavelength bands with a single device, whose cost can be shared by all the subscribers. While at each ONU, OCDMA decoding could be simultaneously carried out by employing a low cost multi-level phase-shifted SSFBG decoder. In addition,

by combining OCDM-PON with WDM technique, high-capacity transmission in access networks can be achieved, which in prospective can enable a 10 Gbps-class, symmetric FTTH.

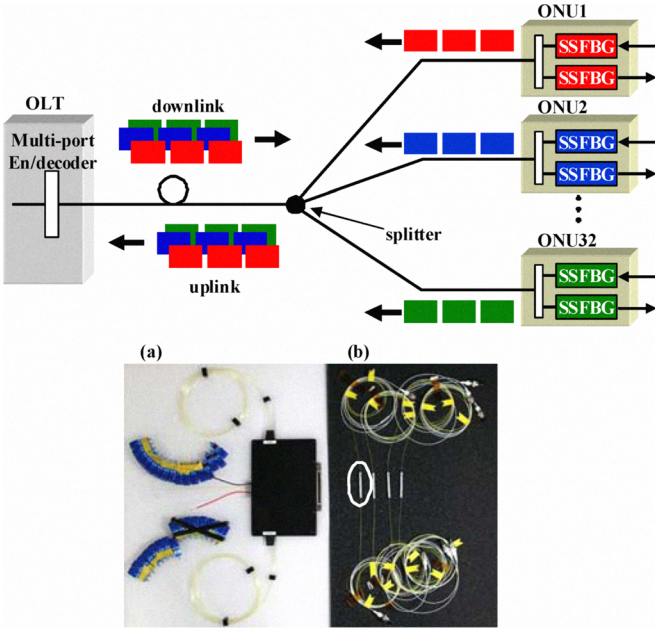

Fig. 1. Architecture of proposed OCDM-PON system and photographs of (a) multi-port (b) SSFBG E/D.

**B. Hybrid Encoder/Decoder**

In this report, we prepare eight apodized 16-chip, 16-level phase-shifted SSFBG E/Ds [11] and a 16x16 port E/D. The SSFBG E/D has the following characteristics: the center wavelength are 1551 nm, chip length is ~0.52 mm, total length of grating is 8.32 mm, the 16 phase levels are generated by shifting the chip grating by a step of  $\pm \lambda/8$ , and each chip is apodized. Here, the apodization technique refers to the refractive index change to approach zero at the end of each grating. It can provide the better encoding performance than a uniform one. Figures 2 show the encoding/decoding waveforms of uniform and apodized SSFBG, respectively. The

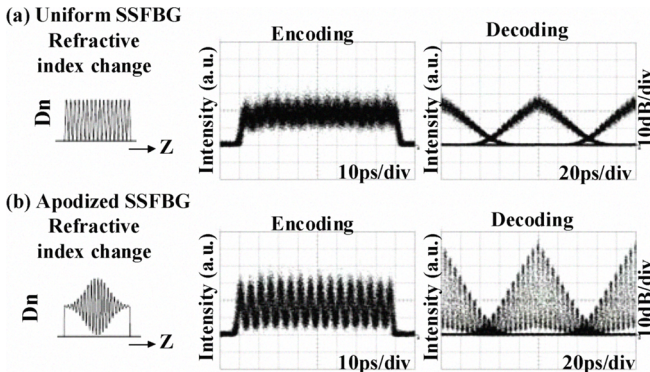

Fig. 2. Refractive index profile, encoding and decoding waveforms of uniform and apodized SSFBGs.

duration of the generated OC is ~80 ps, chip-rate 200 Gchip/s. The peaks of each individual chips of encoding/decoding waveforms generated from the uniform SSFBG is not clear. On the other hand, the apodized SSFBG generates clear encoding/decoding waveforms compared with uniform one. The patterns for SSFBGs OC-1 to 8 correspond to the OCs generated from the 16x16 port encoder with input odd ports, output port 8, respectively. The frequency deviation (channel spacing) between neighboring ports of 16x16 port encoder is 12.5 GHz. The gratings were simply packaged that is 45 mm x 3 mm in size without temperature control.

Figures 3 (a-c) show waveforms of the input pulse and the generated OCs encoded by the 16x16 port and SSFBG encoder, respectively. Figures 3 (d, e) show waveforms of the auto-correlation with different combinations of 16x16 port and SSFBG E/Ds. They are quit similar showing that the 16x16 port and SSFBG E/D can work with each other.

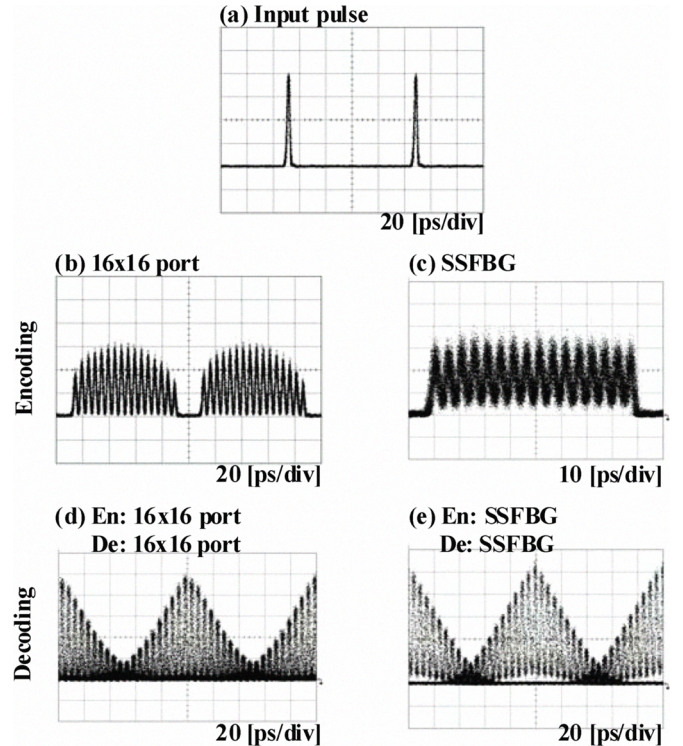

Fig. 3. Waveforms of (a) input pulse, (b), (c) encoded signals, and (d), (e) decoded

Generally, in a coherent OCDMA, where the time-spreading factor is  $N$  ( $N$ : length of code), the interference level is  $\xi = 1/(N \cdot PCR)$ . PCR (power contrast ratio) (dB) shows the difference between auto- and cross-correlation power of decoding output. As an example, to support ten active users in a coherent OCDMA network with chip-rate detection,  $\xi$  should be lower than -27 dB [12]. We need  $\geq 500$ -chip OCs with PCR  $\sim 0$  [13]; but if PCR=10dB, a 50-chip code can work properly, and if PCR increases up to 20 dB, 5-chip codes are sufficient. Therefore, a new method to reduce  $\xi$ , without employing ultralong OC and high chip rate, is to use OCs with ultrahigh PCR. Figure 4 shows the PCR of 16x16port encoder/SSFBG

decoders. PCR of 16-chip (200 Gchip/s), 16-level phase-shifted codes generated by the 16x16 port encoder can be as high as >15 dB, and  $\xi$  is significantly reduced. It can suppress coherent beat noise and MAI and achieve 8 multiplexed users. These performances verify the feasibility of hybrid multi-port and multiphase-level phase-shifted SSFBG E/D to enable flexible and cost-effective OCDM-PON system.

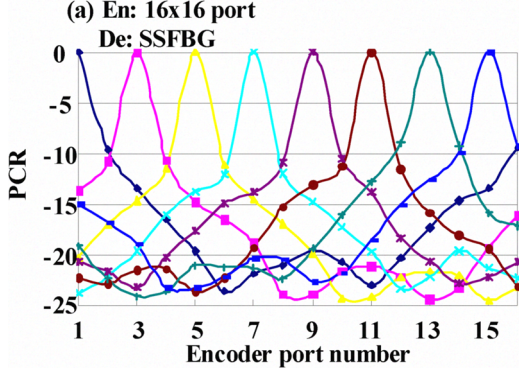

Fig. 4. PCR for 16x16 port and SSFBG decoders.

### III. FULL-DUPLEX EXPERIMENT

Figure 5 shows the experimental setup of full-duplex OCDM system [14]. In this experiment, we simultaneously transmitted both down- and up-link. It means the full-duplex demonstration. OCDM Tx consists of a mode-locked laser diode (MLLD), a LiNbO<sub>3</sub> phase modulator (LN-PM), and erbium-doped fiber amplifiers (EDFAs). The MLLD generates 1.8 ps optical pulses at the repetition rate of 10.71 GHz with the

central wavelength of 1551 nm. The generated signal was modulated with the DPSK format by the LN-PM. The frame contains  $2^{31}-1$  pseudo random bit sequence (PRBS) payload and forward error correction (FEC) parity. Please note that the use of FEC at 10Gbps in FTTH systems will likely become a real-world scenario because of the low-cost. The FEC is Reed-Solomon code (RS(255, 239)). The data rate is 10.71 Gbps (10 G for payload + 7% FEC overhead). An OCDM Rx consists of a fiber-based interferometer and a dual-pin photo diode for the DPSK detection. In this experiment, we employ the clock-and-data recovery (CDR) circuit and the error detector (ED) after the DPSK detection for the bit error rate (BER) measurement.

In downlink, the output of OCDM Tx (Fig. 5 (i)) is split into 8 branches in a truly-asynchronous manner with equal power, random delay, random bit phase and launched into the multi-port encoder, which simultaneously generates eight 16-chip (200 Gchip/s) OCs as shown in Fig. 5 (ii). These 8-OCDMA signals are multiplexed (as shown in Fig. 5 (iii)) and then launched into 50 km transmission fiber, which is composed of a fiber pair of a single mode fiber (SMF) with a reversed dispersion fiber (RDF). After the fiber transmission, these OCDMA signals are split into 8 ONUs. Total loss budget from the OCDM Tx at the OLT to Rx at each ONU is about 30 dB, including 3 dB couplers, connectors, 50 km fiber, and the splitting loss. At each ONU, the received signal was decoded by the 16-chip, 16-phase-shifted SSFBG decoder as shown in Fig. 5 (iv). The decoded signal was detected by the OCDM Rx. Insets (v, vi) in Fig. 5 show the eye diagrams of signals after the DPSK detector and CDR, respectively.

In uplink, as well as downlink, the output of OCDM Tx (Fig. 5 (vii)) is split into 8 branches in a truly-asynchronous manner

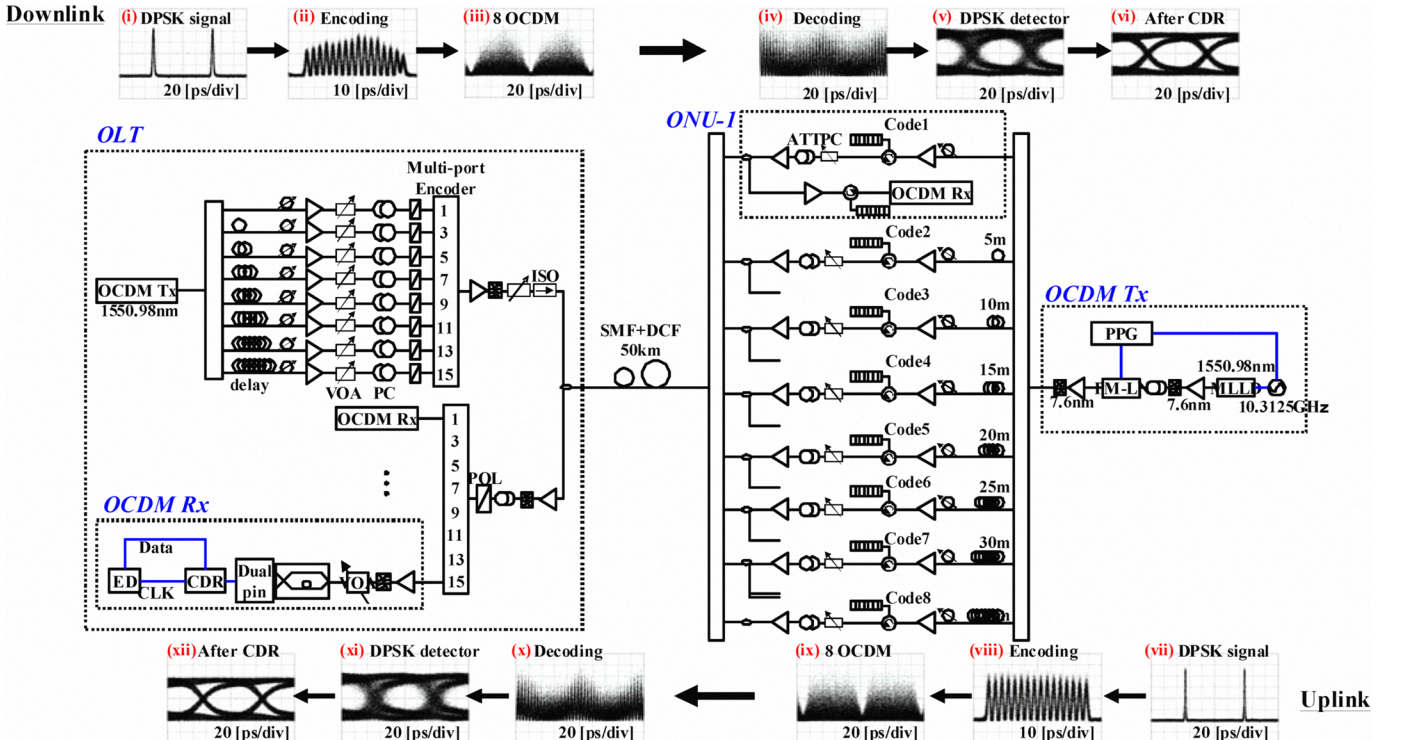

Fig. 5. Experimental setup.

and launched into 8 different SSFBG encoders, which are the same codes as downlink, respectively. Inset (viii) in Fig.5 shows the waveform of the generated OC. The 8-OCDMA signals are asynchronously multiplexed as shown in Fig. 5 (ix), and then launched into 50 km fiber. At the OLT, the 8-OCDMA signals are simultaneously decoded by the multi-port decoder. The decoded signal is detected the same method as downlink. Insets (x, xi, and xii) in Fig. 5 show the eye diagrams of signals after the OCDM decoder, DPSK detector, and CDR, respectively.

Figures 6 show BER performances of up- and down-link after 50 km fiber transmission in case of unidirectional and full-duplex with/without FEC. In full-duplex with FEC, error free ( $BER < 10^{-9}$ ) transmission has been achieved for all the users in both down- and up-link after 50 km transmission. The power penalties of up- and down-link BERs between unidirectional and full-duplex are mainly caused by back reflected noises resulting from connectors, couplers, and other optical devices.

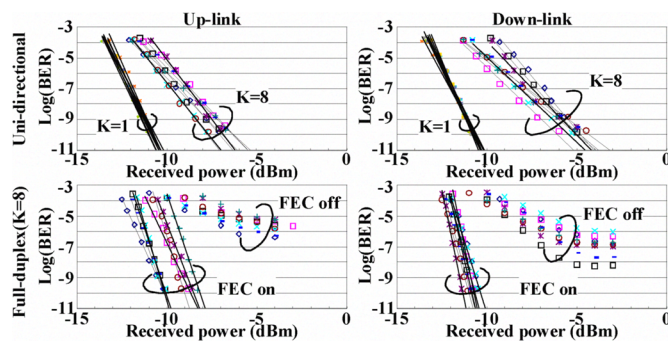

Fig. 6. Measured BERs.

#### IV. CONCLUSION

We report 10 Gbps-class, bandwidth-symmetric, OCDM-PON system using the hybrid multi-port and SSFBG encoder/decoder. Error free ( $BER < 10^{-9}$ ) transmission of bandwidth-symmetric full-duplex, fully-asynchronous, DPSK-OCDMA system with 10Gbps of both up- (8-user) and down- (8-user) link on the same wavelength using hybrid multi-port and SSFBG en/decoder are successfully demonstrated. Recently, 1.24 Tbps (5WDM x 25 OCDM) downlink transmission using multi-port E/D has been demonstrated [15]. Therefore, the proposed OCDMA system could be potentially upgraded over 125 users. Very recently, 10Gbps OCDMA PON system with colorless and sourceless ONUs is proposed and demonstrated [16]. It provides the reduction of equipment cost at each ONU, which does not require any source. In addition, the ONU receivers are identical (colorless), which is one of the key requirement from network operators.

#### ACKNOWLEDGMENT

The authors would like to thank Mr. Hiroyuki Sumimoto of NICT for their support in this experiment.

#### REFERENCES

- [1] K. Kitayama, X. Wang and N. Wada, "OCMA Over WDM PON—Solution Path to Gigabit-Symmetric FTTH," *J. Lightw. Technol.*, vol. 24, no. 4, pp. 1654-1662, April 2006.
- [2] L. G. Kazovsky, W. Shaw, D. Gutierrez, N. Cheng, and S.-W. Wong, "Next-Generation Optical Access Networks," *J. Lightw. Technol.*, vol. 25, no. 11, pp. 3428-3442, Nov. 2007.
- [3] D. K. Mynbaev, "PON performance improves with multiplexing," *WDM Solutions*, pp.18-20, Jan. 2003.
- [4] X. Wang, N. Wada, T. Miyazaki, G. Cincotti, and K. Kitayama, "Field Trial of 3-WDM x 10-OCMA x 10.71-Gb/s Asynchronous WDM/DPSK-OCMA Using Hybrid E/D Without FEC and Optical Thresholding," *J. Lightw. Technol.*, vol. 25, no. 1, pp. 207-215, Jan. 2007.
- [5] S. Etemad, P. Toliver, R. Menendez, J. Young, T. Banwell, S. Galli, J. Jackel, P. Delfyett, C. Price, and T. Turpin, "Spectrally Efficient Optical CDMA Using Coherent Phase-Frequency Coding," *IEEE Photon. Technol. Lett.*, vol. 17, no. 4, pp. 929-931, Apr. 2005.
- [6] V. J. Hernandez, W. Cong, R. P. Scott, C. Yang, N. K. Fontaine, B. H. Kolner, J. P. Heritage, and S. J. B. Yoo, "320-Gb/s Capacity (32 Users x 10 Gb/s) SPECTS O-CDMA Local Area Network Testbed," in *Proc. Optical Fiber Communication Conference and National Fiber Optic Engineers Conference (OFC/NFOEC 2006)*, PDP45, Anaheim, U.S.A, 5-10, Mar. 2006.
- [7] X. Wang, N. Wada, G. Cincotti, T. Miyazaki, and K. Kitayama, "Demonstration of Over 128-Gb/s-Capacity (12-User x 10.71-Gb/s/User) Asynchronous OCDMA Using FEC and AWG-Based Multiport Optical Encoder/Decoders," *IEEE Photon. Technol. Lett.*, vol. 18, no. 15, pp. 1603-1605, Aug. 2006.
- [8] G. Cincotti, N. Wada, and K. Kitayama, "Characterization of a Full Encoder/Decoder in the AWG Configuration for Code-Based Photonic Routers-Part I: Modeling and Design," *J. Lightw. Technol.*, vol. 24, no. 1, pp. 103-112, Jan. 2006.
- [9] X. Wang, K. Matsushima, A. Nishiki, N. Wada, F. Kubota, and K. Kitayama, "High-performance optical code generation and recognition by use of a 511-chip, 640-Gchip/s phase-shifted superstructured fiber Bragg grating," *OSA Optics Lett.*, vol. 30, no. 4, pp. 355-357, Feb. 2005.
- [10] X. Wang, N. Kataoka, N. Wada, T. Miyazaki, G. Cincotti, and K. Kitayama, "Flexible 10 Gbps, 8-User DPSK-OCMA System with 16\*16 Ports Encoder and 16-Level Phase-Shifted SSFBG Decoders," in *Proc. Optical Fiber Communication Conference and National Fiber Optic Engineers Conference (OFC/NFOEC 2008)*, OMR2, San Diego, U.S.A, 24-28, Feb. 2008.
- [11] N. Kataoka, X. Wang, G. Cincotti, N. Wada, and K. Kitayama, "Performance Improvement of 16-Level-Phase-Shifted SSFBG Encoder/Decoder for OCDMA System using Apodization Technique," in *Proc. 14th OptoElectronics and Communications Conference (OECC 2009)*, WN2, Hong Kong, 13-17, July 2009.
- [12] X. Wang and K. Kitayama, "Analysis of Beat Noise in Coherent and Incoherent Time-Spreading OCDMA," *J. Lightw. Technol.*, vol. 22, no. 10, pp. 2226-2235, Oct. 2007.
- [13] X. Wang, T. Hamanaka, N. Wada, A. Nishiki, and K. Kitayama, "10-user, truly-asynchronous OCDMA experiment with 511-chip SSFBG en/decoder and SC-based optical threshold," in *Proc. Optical Fiber Communication Conf. and Nat. Fiber Optic Engineers Conf. (OFC/NFOEC)*, PDP33, Anaheim, CA, Mar. 2005.
- [14] N. Kataoka, X. Wang, G. Cincotti, Y. Terada, N. Wada, and K. Kitayama, "8x8 Full-duplex Demonstration of Asynchronous, 10Gbps, DPSK-OCMA System using Apodized SSFBG and multi-port En/Decoder," in *Proc. 35th Eur. Conf. Optical Communication (ECOC)*, 6.5.5, Vienna, Austria, 20-24, Sep. 2009.
- [15] X. Wang, N. Wada, N. Kataoka, T. Miyazaki, G. Cincotti, K. Kitayama, "100 Km Field Trial of 1.24 Tbit/s, Spectral Efficient Asynchronous 5 WDMx25 DPSK-OCMA using One Set of 50x50 Ports Large Scale En/Decoder," in *Proc. Optical Fiber Communication Conference and National Fiber Optic Engineers Conference (OFC/NFOEC 2007)*, PDP14, Anaheim, U.S.A, 25-29, Mar. 2007.
- [16] G. Cincotti, N. Kataoka, N. Wada, X. Wang, T. Miyazaki, and K. Kitayama, "Demonstration of Asynchronous, 10Gbps OCDMA PON system with Colorless and Sourceless ONUs," in *Proc. 35th Eur. Conf. Optical Communication (ECOC)*, 6.5.7, Vienna, Austria, 20-24, Sep. 2009.