

# Photonic spectral encoder/decoder using an arrayed-waveguide grating for coherent optical code division multiplexing

Hiroyuki Tsuda<sup>(1)</sup>, Hirokazu Takenouchi<sup>(1)</sup>, Tetsuyoshi Ishii<sup>(1)</sup>, Katsunari Okamoto<sup>(2)</sup>, Takashi Goh<sup>(2)</sup>, Kenji Sato<sup>(3)</sup>, Akira Hirano<sup>(3)</sup>, Takashi Kurokawa<sup>(4)</sup>, and Chikara Amano<sup>(1)</sup>

<sup>(1)</sup>NTT Photonics Laboratories, 3-1 Morinosato-Wakamiya, Atsugi, Kanagawa, 243-0198 Japan  
<sup>(2)</sup>NTT Photonics Laboratories, 162 Shirakata-Shirane, Tokai, Ibaragi, 319-1196 Japan  
<sup>(3)</sup>NTT Network Innovation Laboratories, 1-1 Hikari-no-oka, Yokosuka, Kanagawa, 239-0847 Japan  
<sup>(4)</sup>Tokyo University of Agriculture & Technology, 2-24-16 Nakamachi, Koganei, Tokyo, 184-8588 Japan  
 Tel. +81-462-40-2825 Fax. +81-462-40-3259 e-mail; tsuda@aecl.ntt.co.jp

Code division multiplexing (CDM) [1]-[3] is the key technology to realize more flexible and dense photonic networks. The variety of codes are very useful for assignment of optical paths, namely, spectral code paths. Efficient spectral encoder and decoder are necessary for such an application. Diffraction grating pairs[1],[2] have been used for encoding and decoding of optical pulses. However, diffraction grating systems do not have sufficient spectral resolution and it is difficult to attach multiple input/output ports. This paper proposes a novel photonic spectral encoder and decoder pair that uses high-resolution arrayed-waveguide gratings (AWGs); their performance is confirmed in a transmission experiment.

We use a reflection-type AWG, which is polarization insensitive, and a spatial phase filter on the spectral plane, as shown in Fig. 1(a). This configuration is also applicable to other photonic signal processing operations[4]-[6]. The input pulses are spectrally decomposed to their frequency components, each phase is modulated by the encoding filter, and the waveform is reformed by the AWG encoder. The light input to a different input port focuses on the filter plane at a different position, as shown in Fig. 1(b). Binary phase encoding with the maximum length sequence (M-sequence) was used. The spectral bit width  $\delta\omega$  was set at  $1/(T_{WD}$ , time slot). The phase function of the filter,  $H_M(\omega)$ , is as follows;

$$H_M(\omega) = \exp[i\pi M_k(\Omega(\omega))], \quad (1)$$

$$\Omega(\omega) = \frac{\omega - \omega_0}{\delta\omega} \bmod(2^k - 1), \quad (2)$$

where  $M_k(x)$  is the  $x$ th element of the  $k$  stage M-sequence,  $\omega$  is the angular frequency,  $\omega_0$  is the center frequency of the AWG and the light source. The output waveform from

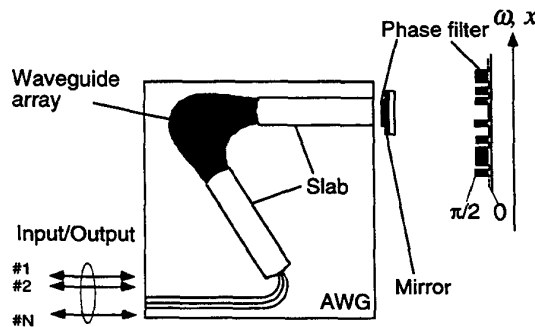

Fig. 1(a) Configuration of the AWG encoder/decoder.

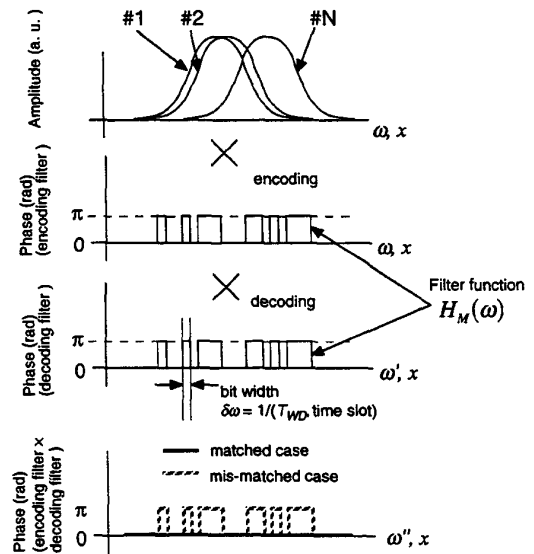

Fig. 1(b) Encoding and decoding method.

the AWG encoder is approximately described as follows;

$$\{f(\tau)e^{i\omega_0\tau}\} * h_M(\tau), \quad (3)$$

where  $f(\tau)$  is the input pulse waveform for the center port and  $h_M(\tau)$  is the Fourier transform of  $H_M(\omega)$ . M-sequence is a pseudo random sequence, so the output waveform is spread out within the time slot without a clear peak. After transmission with dispersion compensation, the signal is again spectrally modulated by the AWG decoder which has the same filter. The waveform output from the AWG decoder is given by

$$\{f(\tau)e^{i\omega_0\tau}\} * F\{H_M(\omega)H_M(\omega')\}. \quad (F; \text{Fourier transform}) \quad (4)$$

When  $\Omega(\omega) = \Omega(\omega')$ , then  $H_M(\omega)H_M(\omega') = 1$  and  $f(\tau)$  is recovered and when  $\Omega(\omega) \neq \Omega(\omega')$ , then  $H_M(\omega)H_M(\omega') = H_M(\omega'')$  and the output waveform duplicates random noise. Therefore, the pulse is recovered only when the spectral positions of the encoding filter and the decoding filter are equivalent.

The experimental setup is shown in Fig. 2. A Fabry-Perot type mode locked laser diode [7] was used for the light source. The repetition frequency was about 20 GHz and the lasing center wavelength was 1549 nm. The 20-GHz pulse train was modulated by lithium niobate (LN) intensity modulator with 10 Gbit/s, return-to-zero (RZ) signal. The width of the pulse input to the AWG encoder was 810 fs when second-order dispersion was compensated for. The pulse width was measured by an autocorrelator on the assumption that the waveform was Gaussian. The diffraction order of the AWG was 72 and the array had 286 waveguides. The spatial dispersion was 1.5 GHz/ $\mu\text{m}$  and the resolution was 12.6 GHz. The spatial phase filter was fabricated by the electron beam lithography of a PMGI thin film on an Au mirror; its phase accuracy was about  $\pi/15$ . M-sequence with 255 bit length was used. The one bit width of the filter was 6.7  $\mu\text{m}$ , which corresponds to 10 GHz. The spectrally encoded 10 Gbit/s, RZ,  $2^{23}-1$  PRBS signal was launched into the 40-km dispersion shifted fiber (DSF), whose total dispersion was +6.6 ps/nm, thence to the dispersion compensating fiber (DCF), decoded by the AWG decoder, and received.

Waveforms at points (A), (B), and (C) on Fig. 2 were measured by a cross- or autocorrelator after dispersion compensation, as shown in Fig. 3(A), (B), (C1)-(C3), respectively. The decoded waveform in the back-to-back configuration (C1) had a clear peak with a width of 1.88 ps when the decoding filter was in the correct position. On the other hand, the decoded waveform (C2) had no clear peak when the position of the decoding filter was shifted an amount more than 2-bits (13.4  $\mu\text{m}$  corresponds to 20 GHz). The decoded waveform after 40-km transmission (C3) also had a clear peak with an autocorrelation width of about 3 ps.

In order to confirm the feasibility of the AWG spectral encoder/decoder, bit error rate (BER) performances were measured, as shown in Fig. 4. The received optical power was measured in front of the EDFA 3. The decoded signal was received by a conventional 10-Gbit/s optical receiver. There was no significant sensitivity penalty up to launched powers ( $P_{in}$ ) of 5 dBm. Error-free (BER <  $10^{-12}$ ) transmission was successfully achieved when  $P_{in}$  was less than 10

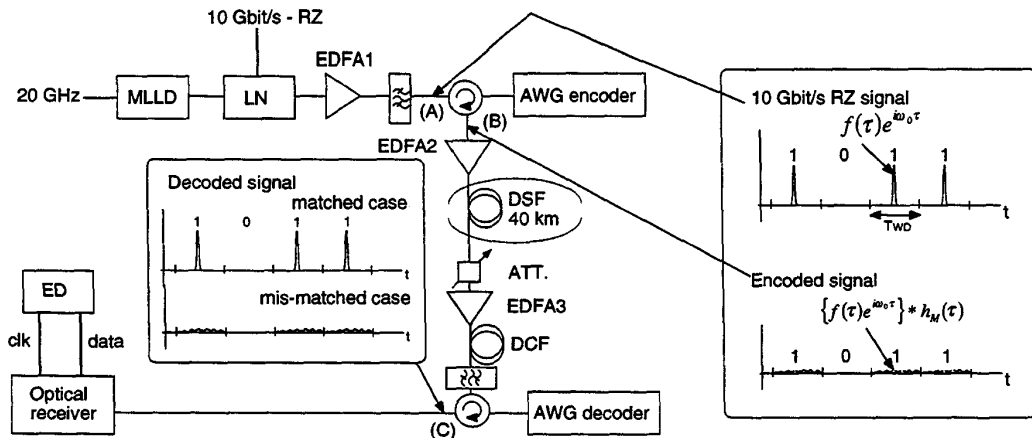

Fig. 2 Experimental setup.

dBm. The high launched power to the DSF with very low dispersion was acceptable because the encoded pulse energy was spread over the time slot.

In conclusion, error-free spectral encoding and decoding of 10 Gbit/s, femtosecond pulses over 40-km transmission fiber was successfully achieved using the AWG photonic spectral encoder and decoder pair.

References

[1] J. A. Salehi, A. M. Weiner, and J. P. Heritage, *J. Lightwave Technol.*, Vol. 8, No. 3, pp. 478-491(1990).  
 [2] H. P. Sardesai, C.-C. Chang, and A. M. Weiner, *J. Lightwave Technol.*, Vol. 16, No. 11, pp. 1953-1964(1998).  
 [3] W. D. Cornwell, N. Wada, K.-I. Kitayama, and I. Andonovic, *Electron. Lett.*, Vol. 34, No. 2, pp. 204-205(1998).  
 [4] H. Tsuda, T. Kurokawa, K. Okamoto, T. Ishii, K. Naganuma, Y. Inoue, and H. Takenouchi, *Technical Digest of ECOC'98*, pp. 533-534, WdC13 (1998).  
 [5] T. Kurokawa, H. Tsuda, K. Okamoto, K. Naganuma, H. Takenouchi, Y. Inoue, and M. Ishii, *Electron. Lett.*, Vol. 33, No. 22, pp. 1890-1891(1997).  
 [6] H. Takenouchi, H. Tsuda, K. Naganuma, T. Kurokawa, Y. Inoue, and K. Okamoto, *Electron. Lett.*, Vol. 34, No. 12, pp. 1245-1246(1998).  
 [7] K. Sato, K. Wakita, I. Kotaka, Y. Kondo, M. Yamamoto, and A. Takada, *Appl. Phys. Lett.*, Vol. 65, pp. 1-3(1994).

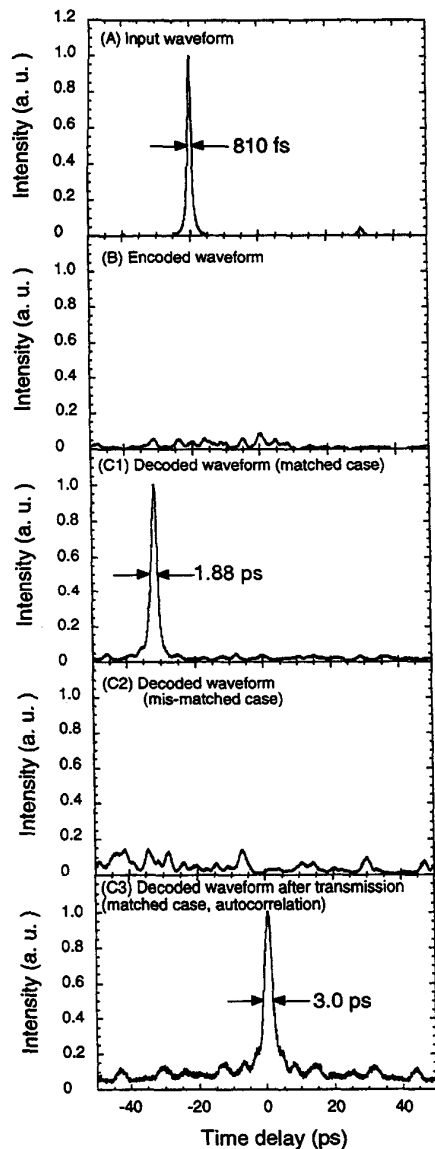

Fig.3 Waveforms at the points of (A), (B), and (C) in Fig. 2. (C1, C2) back-to-back, (C3) after transmission.

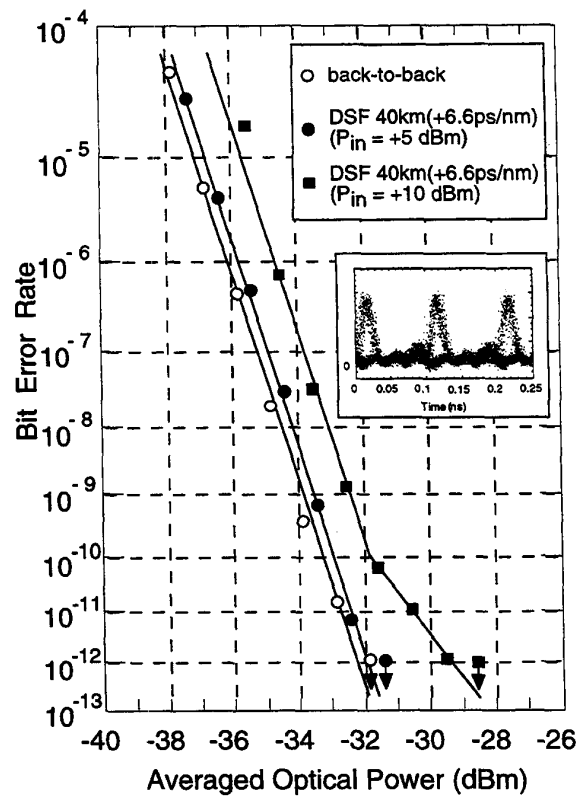

Fig. 4 BER performances of the AWG encoder/decoder. Received optical power was measured in front of the EDFA 3.