

580.439/639 Homework #6

Due November 10, 2014

Problem 1

In class, the cable equation was derived assuming that the membrane impedance consists of a parallel combination of a capacitance c_m and a linear conductance $g_m = 1/r_m$. In some circumstances, it is useful to have a slightly more general model, as drawn below, where the membrane impedance z_m is not specified, except to assume that it is linear (Koch, *Biol Cybern* 50:15, 1984). For the case derived in class, $z_m = 1/(g_m + sc_m)$, where s is the Laplace transform variable.

Part a) Derive the cable equation for the system drawn at right by assuming that z_m is a complex impedance and deriving a Fourier transformed version of the cable equation.

Part b) Assume that the cable is semi-infinite (i.e. extends from an end at $x=0$ to infinity) and is driven by an impulse current $I_0\delta(t)$, where $\delta(t)$ is the Dirac delta, at $x=0$. Argue that the impulse response of the system, in Fourier transformed form, is

$$V(x, j\omega) = I_0 \frac{r_i}{\gamma} e^{-\gamma x}$$

Give an expression for γ in terms of the parameters of the model.

Part c) γ as derived above is a complex number, a function of frequency; it can be treated as an A.C. space constant for the model in the following sense. Write γ as $g+jh$. Argue that $g(\omega)$ is a measure of how far a disturbance at frequency ω spreads along the cylinder. What is $h(\omega)$? (Hint: the potential at frequency ω in the cylinder is $\text{Re}[V(x, j\omega)e^{-j\omega t}]$.)

Part d) In order to get an idea of what the A.C. space constant means, assume that $z_m = 1/(g_m + j\omega c_m)$. What is the relationship between the A.C. length constant, shown above to be $1/g$, and the D.C. space constant λ ? How does the A.C. space constant vary with frequency ω ?

Part e) Suppose the membrane contains a leakage conductance and a Hodgkin-Huxley type delayed-rectifier potassium channel. Derive an expression for z_m which is accurate for small signals near the resting potential (Hint: in a previous homework problem, you showed that a HH delayed rectifier channel is approximately equal to an inductor in series with a resistor). Show that this sort of cable can show a resonance. For example, it would be sufficient to show that the input admittance of the cable Y_∞ can show a resonance.

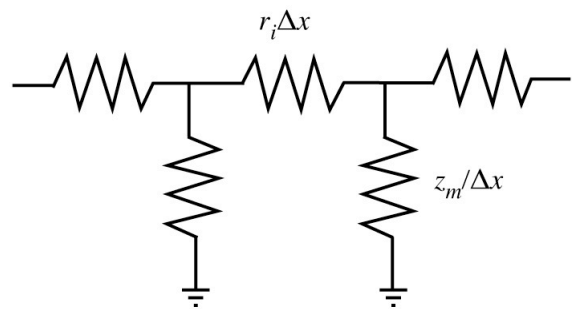

Problem 2

The derivation of the cable equation can be used to gain some useful understanding of potentials recorded extracellularly from neurons. For this problem, we do not assume that r_e is small enough to be ignored.

Part a) Show that, for a cable of finite length

$$\frac{\partial V_e}{\partial x} = -\frac{r_e}{r_e + r_i} \frac{\partial V}{\partial x}, \tag{*}$$

where r_e and r_i are external and axoplasmic resistance/length, V_e is extracellular potential, and V is transmembrane potential. You will have to argue that $i_i = -i_e$ to derive Eqn. (*).

Part b) Use Eqn. (*) to show that for a cylinder with a smashed end (see figure below), the external potential at a point x is given by V_e^* where

$$V_e^*(x) = -\frac{r_e}{r_e + r_i} V(x).$$

$V(x)$ is the transmembrane potential at point x and $V_e^*(x)$ is the extracellular potential at point x relative to the potential at the smash. It is further assumed that the smash shorts the axon at the point of the smash, i.e. that transmembrane potential $V=0$ at the smash (Hint: integrate Eqn. (*)).

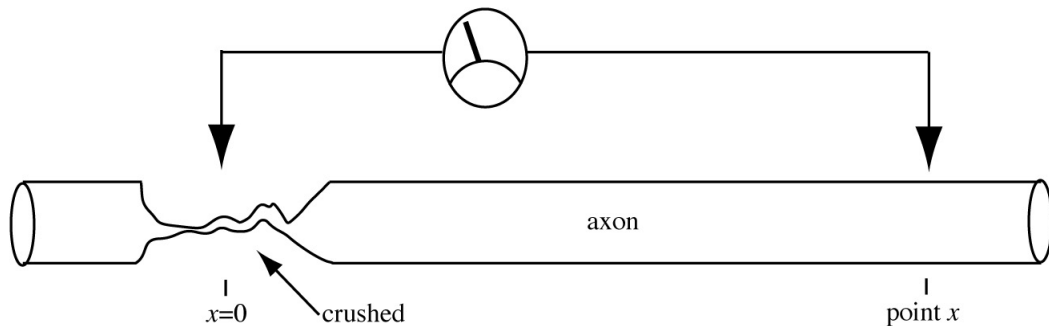

Part c) Some neural structures are like that drawn below in that the neurons are lined up in parallel. An electrode is driven through the structure along the path marked by the distance scale. What is the electrical potential that will be measured by this electrode at various points along its path if the cells are stimulated to produce a simultaneous antidromic action potential in all neurons? In this situation, the extracellular potentials can be assumed to vary unidimensionally, i.e. along the track of the electrode only. The membrane current density profile in each cell that results from the action potentials is drawn at left. Assume that the membrane current is identical in all cells. Hint: an equation was derived in class that relates $V_e(x,t)$ to $i_m(x,t)$.

